

MAZZOLA ENGINEERING

Mechanical Engineers & Consultants since 1976

NEW GENERATION AUTOMATIC UNIVERSAL ENDWELDER

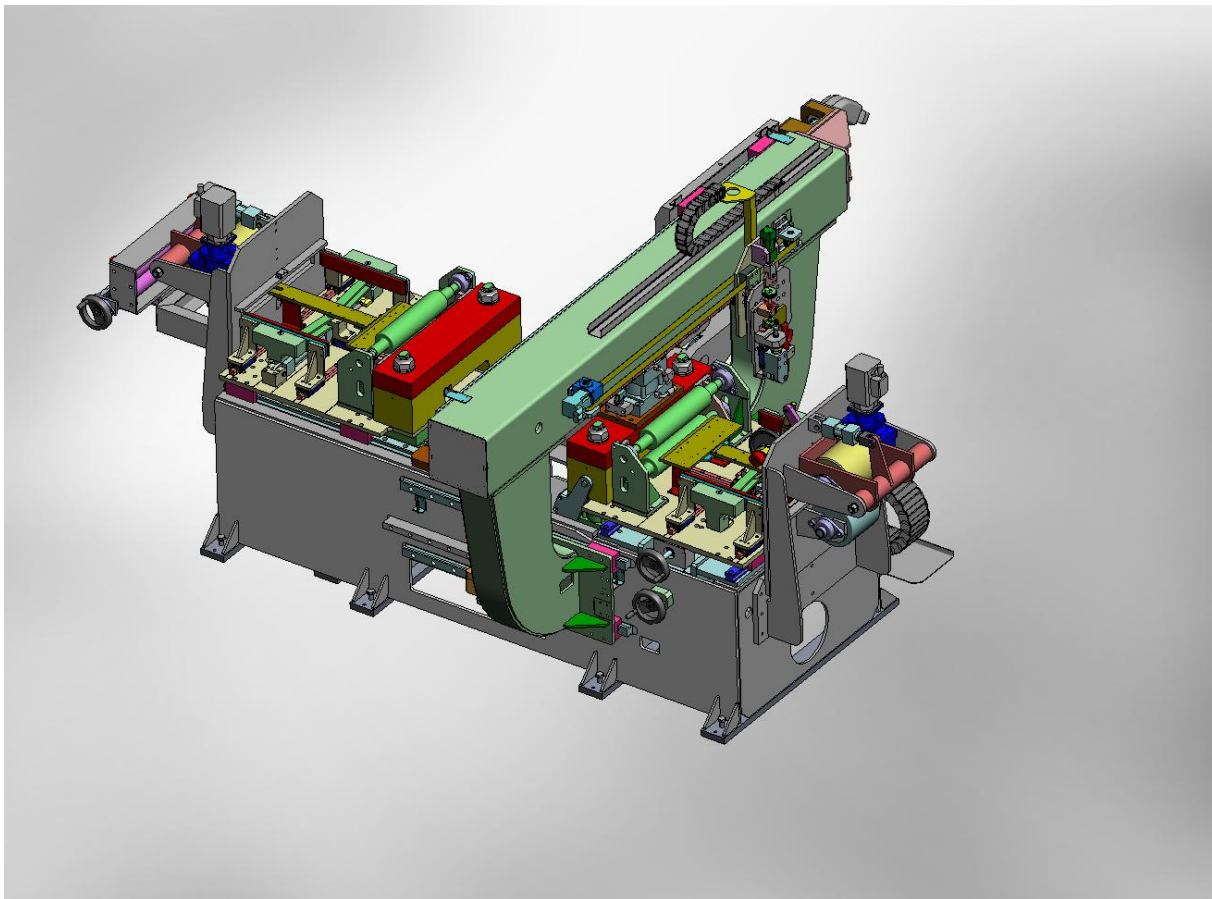



MAIN FEATURES:

- Perfect C/L alignment of incoming with outgoing strip
- **Force absorbing "Scissor-Type" Cutter**
- **Adjustable cutting length**
- Built-in Weld Test
- Built-in Weld Recognition
- Available with different Welding Systems
- Integrated Weld Bead Milling (Optional)

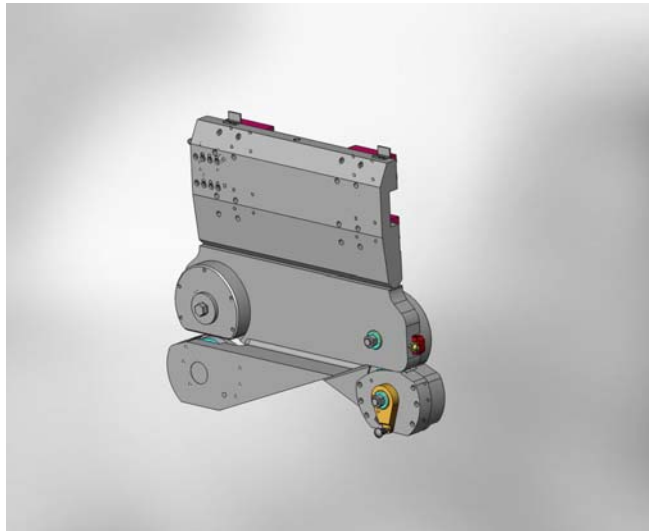

Developed supported by the extensive experience of OEMB and MAZZOLA ENGINEERING the NEW-GENERATION SERIES of Automatic, Universal Endwelders BGN500 & BGN800 combine state-of-the-art technology with the endusers' requirements.

EXCELLENCE IN ENGINEERING AND PERFORMANCE

The result is an advanced, high-performing, flexible and reliable machine, easy to operate and to maintain.

The machine can be integrated into new as well as into existing strip entry lines. Best performance results are achieved when installing the machine in connection with other OEMB entry line components.

HIGH-PERFORMANCE, RELIABLE, FLEXIBLE, EASY TO OPERATE

- BGN500 100/500 mm width
 0.8/4.5 mm thickness
- BGN800 200/800 mm width
 1.0/8.0 mm thickness

COMPREHENSIVE YET COMPACT, ROBUST, LOW MAINTENANCE DESIGN

OEMB New-Generation Series of Universal Endwelders are comprehensive of all necessary components to perform as a stand-alone unit and consequently easily fit into existing strip entry lines.

- Integrated Entry and Exit Pinch-Rolls
- Self-Adjusting Strip Centering Units
- Force-Absorbing, Scissor-Type Double Cutter
- Adjustable Cutting Length
- Built-in Weld Test
- Built-in Weld Recognition
- Available With Different Welding Systems and Processes
- Integrated Optional Weld Bead Milling

OEMB - MAZZOLA ENGINEERING

BGN-500 / -800 Technical Specifications

	BGN-500	BGN-800
STRIP DIMENSIONS		
Strip width min	100 mm - 3.9 in	200 mm - 7.8 in
Strip width max	500 mm - 20 in	800 mm - 31.5 in
Strip thickness min	0.9 mm - .04 in	0.9 mm - .04 in
Strip thickness max	8.0 mm - .32 in	8.0 mm - .32 in
Material quality	Ferrous & non-ferrous	Ferrous & non-ferrous
INFEED		
Entry strip leading unit	Manual adjustment	Manual adjustment
Entry PR closing actuator	Hydraulically operated	Hydraulically operated
Entry PR drive	AC Servodrive	AC Servodrive
Entry PR opr speed range	0 - 20 m/' (65 FPM)	0 - 20 m/' (65 FPM)
Centering unit actuator	Hydraulically operated	Hydraulically operated
Centering unit adjustment	Selfadjusting to strip width	Selfadjusting to strip width
CLAMPING		
Clamping unit actuator	Hydraulically operated	Hydraulically operated
Clamping unit positioning	Hydraulically operated	Hydraulically operated
Weld gap adjustment	Manual adjustment	Manual adjustment
EXIT		
Exit PR closing actuator	Hydraulically operated	Hydraulically operated
Exit PR drive	Hydraulically operated	Hydraulically operated
Exit PR opr speed range	0 - 20 m/' (65 FPM)	0 - 20 m/' (65 FPM)



POSITIONING		
Strip positioning	Automatically preset or operator controlled for variable cutting length	Automatically preset or operator controlled for variable cutting length
Components' carriage Speed	Up to 200 mm/' (40 FPM)	Up to 200 mm/' (40 FPM)
CUTTING		
Double Cutter actuator	Hydraulically operated	Hydraulically operated
Cutting speed	100 mm/' @ 8.0 mm (4 In/sec @ .32")	100 mm/' @ 8.0 mm (4 In/sec @ .32")
Roller-Blades	Manual adjustment to strip width	Manual adjustment to strip width
Blades change-over	Quick-change system	Quick-change system
WELDING		
Welding process	- TIG up to 5.0 mm (.2") - MIG-MAG over 5.0 mm - Plasma	- TIG up to 5.0 mm (.2") - MIG-MAG over 5.0 mm - Plasma
Welding torch drive	AC Servodrive	AC Servodrive
Welding speed range	0 - 30 mm/' (6 FPM)	0 - 30 mm/' (6FPM)
Welding speed setting	Operator's panel selector	Operator's panel selector
Welding head adjustment	Manual adjustment	Manual adjustment
Quick "lift-off" positioning	Hydraulically operated	Hydraulically operated
Welding range setting	Automatically preset to strip width	Automatically preset to strip width
Welding power setting	Operator's panel selector	Operator's panel selector
Welding copper plate	Retractable, Hydraulically operated	Retractable, Hydraulically operated
EXTRA FEATURES		
Weld recognition marking	Integrated in Exit Clamping unit, Hydraulically operated	Integrated in Exit Clamping unit, Hydraulically operated
Weld test	Integrated in Entry Clamping unit, Hydraulically operated	Integrated in Entry Clamping unit, Hydraulically operated



OPTIONALS		
Weld bead milling	Integrated in Welding Torch Holder	Integrated in Welding Torch Holder
Design Autocycle Time	41 seconds max	41 seconds max
Design Conformity	CE certificate type B	Certificate type B
Machine weight	Approx. 5000 kg	Approx 5000 kg
COMPONENTS	Included:	Included:
	Machine frame	Machine frame
	Entry Strip Leading Unit	Entry Strip Leading Unit
	Entry Pinch Roll	Entry Pinch Roll
	Entry Centering Unit	Entry Centering Unit
	Entry Clamping Unit	Entry Clamping Unit
	Exit Clamping Unit	Exit Clamping Unit
	Exit Centering Unit	Exit Centering Unit
	Exit Pinch Roll	Exit Pinch Roll
	Components' Carriage	Components' Carriage
	Double Cutter	Double Cutter
	Welding Torch Holder	Welding Torch Holder
	Weld Recognition	Weld Recognition
	Weld Test System	Weld Test System
	Drives & Actuators	Drives & Actuators
	Hydraulic Power Pack	Hydraulic Power Pack
	Electrical Cabinet	Electrical Cabinet
	Operator's Panel	Operator's Panel
	All cables & Piping on board	All cables & Piping on board
	CE-Operator's Manual	CE-Operator's Manual
	Not included:	Not included:
	Power supply cables	Power supply cables
	Welding unit	Welding unit
	Protection fences and barricades	Protection fences and barricades
	On-site Commissioning	On-site Commissioning



Description of Automatic Operating Sequences

The machine is equipped with an interactive control allowing for operator's guided automatic operating sequences.

Machine set-up for a given strip format

When first introducing strip the operator presets the cutting positions of coil end and new coil with the aim of obtaining a clean and perpendicularly precise edge for best welding result.

This is done by activating a pushbutton after manually positioning the strip in the desired position.

The welding start and end points are also preset using the same teach-in method. When changing strip thickness an adjustment of the cutter's knives is also required. The set-up sequence is completed by selecting "automatic mode" on the panel.

Operator's controlled automatic operating sequences

MAZZOLA ENGINEERING's philosophy is to always involve the operator in all automatic sequences. Consequently great attention has been paid to the development of the man-machine interface.

The BGN series of Endwelders combine different functions: positioning of coil end and new coil, cutting of coil end and new coil, positioning for welding, welding, weld testing, weld position marking and, in case of MIG-MAG welding process, optional milling of the upper weld bead.

These functions have been divided into 4 main autosequences, initiated and controlled by the operator.

When coil is run through the machine all elements are in their respective open-and-retracted positions. Coil "almost depleted" is announced by a signal from the uncoiler system and used to reduce decoiling speed to a fixed value, i.e. 20 m/'. The coil end leaving the uncoiler system is detected by a sensor (installed after the uncoiler and usually commanding the closure of the flattener/leveller). The same signal starts the exit pinch-roll of the BGN which will be driven at the current strip speed (i.e. 20 m/'). As soon as the coil end enters the BGN the exit pinch-roll automatically closes and ramps-down the speed to stop the strip in the exit clamp at the preset position. A speed signal is given by the BGN to the subsequent entry line unit (i.e. strip accumulator) synchronizing its drive with the exit pinch-roll.



Sequence 1: COIL END

When the strip is stopped the operator receives a ready signal for the first autosequence. Having made sure that the strip is in the correct position the operator initiates the sequence by pushing the only illuminated button (dark panel).

This sequence includes closing of the exit centering unit, closing of the exit clamp, moving of the cutter in the "coil end cutting" position, cutting of coil end. In the meantime the operator will have brought a new coil, opened its strap and advanced the coil head into the preceding unit (i.e. the flattner/leveller) which will introduce it into the BGN's entry pinch-roll. There the strip is detected by a sensor which commands the closing of the entry pinch-roll which in turn drives the strip to the preset position for cutting.

Sequence 2: NEW COIL

When the incoming strip is stopped the operator receives a ready signal for the second autosequence. Having made sure that the strip is in the correct position the operator initiates the sequence by pushing the only illuminated button (dark panel).

This sequence includes closing of the entry centering unit, closing of the entry clamp, moving of the cutter in the "new coil cutting" position, cutting of new coil, advancing the entry clamps unit into the preset welding position and rising of the copper welding support.

At this point the strip edges have come together ready to be welded. The machine allows for small lateral adjustments of the strip should this become necessary.

Sequence 3: WELDING

Having visually checked the the correct strip edges position the operator initiates the third autosequence by pushing the only illuminated button (dark panel). The welding operation is automatically performed. The machine allows for welding gap adjustment. Welding parameters are to be set according to the welding process and unit in use.



Weld test and weld position marking

The machine is provided with two functions that can be optionally activated if required:

- If activated the weld test is performed immediately after welding is completed. The strip will then be subjected to traction during 2 seconds.
- If activated the weld position marking unit integrated into the exit clamp will punch the coil end, marking the weld position for downstream recognition.

Sequence 4: **END**

Having visually checked the welding result the operator initiates the final autosequence by pushing the only illuminated button (dark panel).

This sequence commands the opening of all units (i.e. pinch-rolls, centering and clamping units) and checks that all elements are into their respective "open-and-retracted" positions allowing for free strip running.

Note:

Machine data, components and operating sequence descriptions are preliminary and subject to change at any time.

v.01/08-Oct2008



